

OWNER'S MANUAL | MANUEL DE L'UTILISATEUR MANUAL DEL PROPIETARIO | HANDBUCH | MANUALE DELL'UTENTE



MODEL / MODÈLE / MODELO / MODELL / MODELLO : PB2BPGG, PB3BPGG
PART / PIÈCE / PARTE / TEIL / PARTE : 10752, 10753, 10754, 10755, 10756, 10757



PIT BOSS®

PORTABLE GAS GRILL

IMPORTANT, READ CAREFULLY, RETAIN FOR FUTURE REFERENCE. MANUAL MUST BE READ BEFORE OPERATING!

GRIL À GAZ PORTABLE

IMPORTANT, PRENEZ CONNAISSANCE DE CE DOCUMENT ET CONSERVEZ-LE POUR RÉFÉRENCE ULTÉRIEURE. VOUS DEVEZ LIRE CE GUIDE AVANT D'UTILISER LE BARBECUE!

BARBACOA DE GAS PORTÁTIL

IMPORTANTE, LEER DETENIDAMENTE, CONSERVAR PARA REFERENCIA FUTURA. LEA EL MANUAL ANTES DEL USO!

For outdoor and household use only. Not for commercial use.
Réservé à l'usage extérieur et résidentiel uniquement. Non destiné à un usage commercial.
Solo para uso doméstico y en el exterior. No apto para uso comercial.
Bitte nur im Freien und privat nutzen. Nicht für die gewerbliche Anwendung geeignet.
Solo per uso domestico ed esterno. Non per uso commerciale.

WARNING: PLEASE READ THE ENTIRE MANUAL BEFORE INSTALLATION AND USE OF THIS GAS APPLIANCE. FAILURE TO FOLLOW THESE INSTRUCTIONS COULD RESULT IN PROPERTY DAMAGE, BODILY INJURY OR EVEN DEATH. CONTACT LOCAL BUILDING OR FIRE OFFICIALS ABOUT RESTRICTIONS AND INSTALLATION INSPECTION REQUIREMENTS IN YOUR AREA.

AVERTISSEMENT : VEUILLEZ LIRE L'INTÉGRALITÉ DU MANUEL AVANT INSTALLATION ET UTILISATION DE CET APPAREIL À GAZ. LE NON-RESPECT DE CES INSTRUCTIONS PEUT ENTRAÎNER DES DOMMAGES MATÉRIELS, DES DOMMAGES CORPORELS OU MÊME LA MORT. CONTACTEZ LES AUTORITÉS LOCALES COMPÉTENTES CONCERNANT LES RESTRICTIONS ET LES EXIGENCES D'INSPECTION EN VIGUEUR DANS VOTRE RÉGION.

ADVERTENCIA: LEA TODO EL MANUAL ANTES DE MONTAR Y USAR ESTA BARBACOA DE GAS. SI NO SE SIGUEN ESTAS INSTRUCCIONES, PUEDEN PRODUCIRSE DAÑOS MATERIALES, LESIONES CORPORALES O INCLUSO LA MUERTE. PÓNGASE EN CONTACTO CON LOS ADMINISTRADORES DEL EDIFICIO O CON LOS BOMBEROS PARA CONSULTAR LAS RESTRICCIONES Y LOS REQUISITOS DE INSPECCIÓN DE LAS INSTALACIONES DE SU ZONA.

ACHTUNG: BITTE LESEN SIE DIE GESAMTE ANLEITUNG SORGFÄLTIG DURCH, BEVOR SIE DIESES GASGERÄT AUFSTELLEN UND BENUTZEN. DIE NICHTBEACHTUNG DIESER ANWEISUNGEN KANN ZU SACHSCHÄDEN, VERLETZUNGEN ODER SOGAR ZUM TOD FÜHREN. FÜR EINSCHRÄNKUNGEN SOWIE MONTAGE- UND KONTROLLAUFLAGEN IN IHRER REGION WENDEN SIE SICH AN DIE GEBÄUDE- ODER BRANDBEAUFTRAGTEN VOR ORT.

AVVERTENZA: LEGGERE L'INTERO MANUALE PRIMA DELL'INSTALLAZIONE E DELL'USO DI QUESTA APPARECCHIATURA A GAS. LA MANCATA OSSERVANZA DELLE ISTRUZIONI PUÒ CAUSARE DANNI ALLA PROPRIETÀ, LESIONI FISICHE O MORTE. CONTATTARE LE AUTORITÀ LOCALI COMPETENTI PER L'EDILIZIA O I VIGILI DEL FUOCO PER INFORMAZIONI SULLE RESTRIZIONI E SUI REQUISITI DI ISPEZIONE DEGLI IMPIANTI NELLA PROPRIA ZONA.

TRAGBARER GASGRILL

WICHTIG: AUFMERKSAM LESEN UND GUT AUFBEWAHREN BITTE UNBEDINGT VOR GEBRAUCH DIE BEDIENUNGSANLEITUNG SORGFÄLTIG DURCHLESEN!

GRIGLIA A GAS PORTATILE

IMPORTANTE: LEGGERE ATTENTAMENTE E CONSERVARE PER RIFERIMENTO FUTURO. LEGGERE IL MANUALE PRIMA DELL'USO.



SAFETY INFORMATION

A MAJOR CAUSE OF FIRES ARE A RESULT OF POOR MAINTENANCE AND A FAILURE TO MAINTAIN REQUIRED CLEARANCES (AIR SPACES) TO COMBUSTIBLE MATERIALS. IT IS OF UTMOST IMPORTANCE THAT THIS PRODUCT BE INSTALLED ONLY IN ACCORDANCE WITH THESE INSTRUCTIONS.

Please read and understand this entire manual before attempting to assemble, operate or install the product. This will ensure you receive the most enjoyable and trouble-free operation of your new portable gas grill. We also advise you retain this manual for future reference.

DANGERS AND WARNINGS

1. A minimum clearance of 915mm (36 inches) from combustible constructions to the sides of the grill, and 915mm (36 inches) from the back of the grill to combustible constructions must be maintained. Do not use this appliance indoors or in an enclosed, unventilated area. This appliance must not be placed under overhead combustible ceiling or overhang. Keep your grill in an area clear and free from combustible materials, gasoline and other flammable vapors and liquids.

Should a grease fire occur, turn the grill OFF until the fire is out. Do not throw water on. Do not try to smother the fire. Use of an all-class (class ABC) approved fire extinguisher is valuable to keep on site. If an uncontrolled fire does occur, call the Fire Department.

2. This outdoor grill is not intended for installation in/on recreation vehicles or boats.

Never use this appliance in an enclosed space, such as a camper, tent, car, boat or home. This appliance is not intended for and should never be used as a heater.

3. This appliance is not recommended for children, persons with reduced physical, sensory or mental capabilities, or lack of experience and knowledge, unless they are under direct supervision or instruction by a person responsible for their safety.
4. Parts of the barbecue may be very hot, and serious injury may occur. Keep young children and pets away while in use. Do not touch hot surfaces. Use heat-resistant gloves, long-handled tongs, or cooking mitts at all times, since the grill will become very hot.
5. Never use the grill without the grease cup installed and hung under the firebox. Without the grease cup, hot grease and debris could leak downward and produce a fire hazard.
6. Do not obstruct the flow of combustion and ventilation air to this appliance. Keep the burner tube and portholes clean and free from debris. Clean before use. Regular care and maintenance is required to prolong the lifespan of your unit.
7. Always check for gas leaks when you connect and disconnect the regulator to the gas cylinder, especially after a period of storage (for example, over winter). Check all connections for leaks with a soapy water solution and brush. Never use an open flame to check for leaks.
8. Clean and inspect the gas regulator before each use of the outdoor cooking gas appliance. Replace the gas regulator prior to being used if there is evidence of excessive abrasion or wear.
9. Operate this appliance using liquefied petroleum only, which is also specified on the rating label on the unit. Do not attempt to operate your grill on other gases. Do not attempt to convert this LP unit to natural gas. Failure to follow this warning could lead to fire, bodily harm, and will void your warranty.

PROPANE GAS WARNINGS

1. Ensure the gas cylinder is purchased by a reputable supplier. An incorrectly filled or an overfilled gas cylinder can be dangerous. The overfilled condition combined with the warming of the gas cylinder (a hot summer day, gas cylinder left in the sun, etc.) can cause LP gas to be released since the temperature increase causes gas to expand. Gas released from the cylinder is flammable and can be explosive.
2. Do not use an LP gas cylinder if it has a damaged valve or shows signs of dents, gouges, bulges, fire damage, corrosion, leakage, excessive rust, or other forms of visual external damage; it may be hazardous and should be checked immediately by a liquid propane supplier.

If you see, smell, or hear the hiss of gas escaping from the cylinder, do not attempt to light appliance. Extinguish any open flame. Disconnect from fuel supply.

3. Do not connect or disconnect the gas cylinder while the unit is in use or is still hot. When grill is not in use, ensure regulator knob is turned to OFF and disconnect the gas cylinder. Never move or transport the unit while the gas cylinder is attached. Do not store a spare LP gas cylinder under or near the appliance.
4. Parts sealed by manufacturer shall not be manipulated by the user. Do not move the appliance during use. Turn off the gas supply at the gas cylinder after use. Do not modify the appliance.

CARBON MONOXIDE ("THE SILENT KILLER")

Always use a gas appliance outdoors in an open area with good ventilation to avoid breathing toxic fumes from combustion or leaking gas. Carbon monoxide is a colorless, odorless, tasteless gas produced by burning gas, wood, propane, charcoal or other fuel. Carbon monoxide reduces the blood's ability to carry oxygen. Low blood oxygen levels can result in headaches, dizziness, weakness, nausea, vomiting, sleepiness, confusion, loss of consciousness or death. Follow these guidelines to prevent this colorless, odorless gas from poisoning you, your family, or others:

- See a doctor if you or others develop cold or flu-like symptoms while cooking or in the vicinity of the appliance. Carbon monoxide poisoning, which can easily be mistaken for a cold or flu, is often detected too late.
- Alcohol consumption and drug use increase the effects of carbon monoxide poisoning.

Carbon monoxide is especially toxic to mother and child during pregnancy, infants, the elderly, smokers, and people with blood or circulatory system problems, such as anemia, or heart disease.

SAFETY LISTING

In accordance with the procedures and specifications by Conformité Européenne (CE), Pit Boss® Grills gas appliances demonstrates compliance through testing to the standards and directives that comply with all safety, health and environmental protection requirements by the EU (European Union) and the European Economic Area (EEA).



	HEAT INPUT	BURNERS	INJECTOR SIZE	GAS/PRESSURE	COUNTRY OF USE
PB2BPGG	5.2 KW G30 – 378 g/h G31 – 372 g/h	2	0.79mm	G30 at 28-30 mbar G31 at 37 mbar G30/G31 mixture at 30 mbar	I3+ (28-30/37) : BE, CH, CY, CZ, ES, FR, GB, GR, IE, IT, LT, LU, LV, PT, SK, SI I3B/P (30) : BE, CY, DK, EE, FR, GB, HU, IT, LT, NL, NO, SE, SI, SK, RO, HR, TR, BG, IS, LU, MT, FI I3B/P (37) : PL I3B/P (50) : AT, DE, SK, CH
			0.74mm	G30/G31 mixture at 37 mbar	
			0.69mm	G30/G31 mixture at 50 mbar	
PB3BPGG	7.5 KW G30 – 546 g/h G31 – 536 g/h	3	0.90 / 0.70mm	G30 at 28-30 mbar G31 at 37 mbar G30/G31 mixture at 30 mbar	I3B/P (37) : PL I3B/P (50) : AT, DE, SK, CH
			0.86 / 0.65mm	G30/G31 mixture at 37 mbar	
			0.80 / 0.60mm	G30/G31 mixture at 50 mbar	



COPYRIGHT NOTICE

Copyright 2020. All right reserved. No part of this manual may be copied, transmitted, transcribed, stored in a retrieval system, in any form or by any means without expressed written permission of,

Dansons

3411 North 5th Avenue, Suite 500, Phoenix, AZ, USA 85013
sales@pitboss-grills.com | service@pitboss-grills.com
www.pitboss-grills.com

Customer Service

Monday through Sunday, 4am - 8pm PST (EN/FR/ES)
Toll-Free: 1-877-303-3134, Fax: 1-877-303-3135

TABLE OF CONTENTS

Safety Information 2

Connecting To A Gas Supply

 Gas Cylinder Requirements..... 5

 Connecting The LP Gas Cylinder..... 5

 Preparation For Use – Leak Testing..... 5

 Disconnecting A Gas Cylinder 6

Operating Instructions

 Grill Environment 7

 First Use – Grill Burn-Off 7

 Lighting Procedure..... 7

 Manual Lighting Procedure..... 8

 Shutting Off Your Grill..... 8

Care & Maintenance 9

Troubleshooting 10

Replacement Parts

 PB2BPGG & Grill Cart 11

 PB3BPGG & Grill Cart 12

Warranty 13

CONNECTING TO A GAS SUPPLY

GAS CYLINDER REQUIREMENTS

To operate, you will need a precision-filled standard G30/G31 grill liquid propane ("LP") gas cylinder with external valve threads. Use standard flexible tube with length less than 1.5 m (59 in). The tube shall be readily visible across its entire length for inspection after installation.

The maximum diameter and the maximum height of the cylinder is 300 mm (11.8 in) and 600 mm (23.6 in) as shown in illustration.

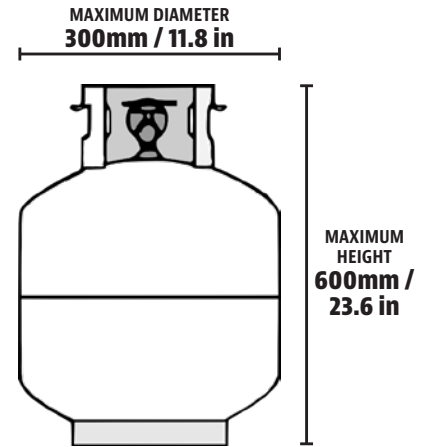

CAUTION: You must have the proper regulator which relevant standard is EN16129 and bottle in order for the barbecue to operate safely and efficiently. Use of an incorrect or faulty regulator is dangerous and will invalidate any warranty. It is important to inspect the full length of the tube. If it is evident there is excessive abrasion or wear, or the tube is cut, the tube must be replaced prior to the appliance being used.

CONNECTING THE LP GAS CYLINDER

IMPORTANT: If the manifold requires a connector, follow the connector installation instructions prior to connecting the unit to a gas cylinder.

1. Before connecting, ensure there is no debris caught in the head of the LP gas cylinder, head of the regulator valve, or in the head of the burner and burner ports.
2. Connect the tube line to the manifold by turning the knob clockwise until it stops. Make sure that the tube is not twisted in any way.
3. Place the LP gas cylinder into the cylinder hole. Ensure the hose connected to the cylinder does not touch any of the grill surfaces that could get hot. Keep the LP gas cylinder in place during operation of the barbecue. Do not place a spare cylinder in the cylinder enclosure at any time. Allow the the LP gas cylinder to be easily accessible (not blocked) at all times. If the LP gas cylinder is too tall, it cannot be put into the cylinder hole. The gas cylinder can be attached to the gas cylinder hook on the right side of the frame or placed on flat ground.
4. Make sure the gas cylinder valve is in OFF position. Ensure the gas cylinder is completely upright, as it is unsafe to operate the grill if the gas cylinder is not installed properly.
5. Ensure the regulator valve on the grill is completely closed by turning the knob clockwise to the OFF position.
6. Remove the protective caps from the regulator valve opening and the top of the gas cylinder. Save the caps.
7. Insert the gas cylinder valve into the threaded opening of the regulator valve. Turn the cylinder clockwise until firm. Hand-tighten only.
8. LP gas cylinder is now installed.

WARNING: Shut off the gas cylinder if you smell gas. Attempt to re-install gas cylinder to ensure that tube is connected properly.

PREPARATION FOR USE – LEAK TESTING

A leak test is used to determine the integrity of a seal. Before using your gas grill, perform a leak test on the connection between the regulator and the gas cylinder to reduce the risk of serious bodily injury or death from fire or explosion. A leak test should be performed a minimum of once a season, as well as:

- before lighting your grill for the first time,
- every time the gas cylinder has been changed,
- after travel, especially over rough or bumpy roads,
- after a prolonged period of storage or non-use.

HOW TO PERFORM A LEAK TEST

Supplies Required:

- 1 x Bowl (*empty, clean*)
- 1 x Paint Brush (*clean*)
- Dish Washing Liquid
- Water

Procedure:

1. Position the grill in a well-ventilated area. Ensure the grill is cool to the touch, and not in use. Verify that the regulator valve is turned to the OFF position and that the gas cylinder is tightened securely to the regulator.

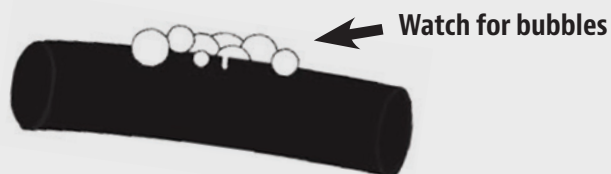

IMPORTANT: Ensure there is no open flame or smokers nearby.

2. Mix a solution of one part of water with one part of dish washing liquid in a bowl. The solution will make bubble, as it will be concentrated.
3. Use a paint brush to apply the solution onto the seal between the regulator and the gas cylinder. Visually inspect for streams of bubbles coming from a defect or break in the seal.

NOTE: If a leak appears, repeat gas cylinder installation procedure, but do not over-tighten. Hand-tighten only. Repeat leak test after re-installation to ensure seal is secure.

IMPORTANT: Do not use the gas grill if you detect a gas leak that cannot be corrected by using the leak test procedure. Contact your local Fire Department or Customer Service for alternative measures of testing to ensure proper precaution.

DISCONNECTING A GAS CYLINDER

IMPORTANT: When changing or disconnecting a gas cylinder, care must be taken to keep away from any source of ignition.

1. Ensure the control knob on the grill is completely closed by turning to the OFF position. Turn LP gas cylinder valve to the CLOSED position, and allow the regulator knob to pop out.
2. Turn the cylinder counter-clockwise (by hand) to disconnect from the regulator valve opening. Replace the protective caps on the regulator valve opening and the top of the gas cylinder for storage (if not empty).

WARNING: Do not transport grill with gas cylinder attached. The cylinder may loosen off the valve, and cause a gas leak, possibly resulting in an explosion, fire, or severe bodily harm. Disconnect gas cylinder first before travel or storage. If storing the grill indoors, leave the gas cylinder outdoors.

OPERATING INSTRUCTIONS

GRILL ENVIRONMENT

1. *WHERE TO SET-UP THE GRILL*

With all outdoor appliances, outside weather conditions play a big part in the performance of your grill and the cooking time needed to perfect your meals. All Pit Boss® Grills units should keep a minimum clearance of 915mm (36 inches) from combustible constructions, and this clearance must be maintained while the grill is operational. This appliance must not be placed under overhead combustible ceiling or overhang. Keep your grill in an area clear from combustible materials, or other flammable vapors and liquids.

2. *COLD WEATHER COOKING*

As it becomes cooler outside, that does not mean that grilling season is over! The crisp cool air and heavenly aroma of grilled foods will help cure your winter blues. Follow these suggestions on how to enjoy your grill throughout the cooler months:

- Organize – Get everything you require ready in the kitchen before you head outdoors. During the winter, move your grill to an area that is out of the wind and direct cold. Check local bylaws regarding the proximity of your grill in relation to your home and/or other structures. Put everything you need on a tray, bundle up tight, and get it done!
- To help keep track of the outside temperature, place an outdoor thermometer close to your cooking area. Keep a log or history of what you cooked, the outdoor temperature, and the cooking time. This will help later down the road to help you determine what to cook and how long it will take.
- Have a heated platter or a dish cover ready to keep your food warm while making the trip back inside.

3. *HOT WEATHER COOKING*

As it becomes warmer outdoors, the cooking time will decrease. Follow these few suggestions on how to enjoy your grill throughout the hot months:

- Adjust your cooking temperatures downward. This helps to avoid unwanted flare-ups.
- Use a meat thermometer to determine the internal temperature of your foods. This helps in preventing your meat from over cooking and drying out.
- You can keep foods hot by wrapping them in foil, and placing them in an insulated cooler. Stuff crumpled up newspaper around the foil and this will keep food hot for 3 to 4 hours.

FIRST USE – GRILL BURN-OFF

Before using your grill for the first time with food, it is important to complete a burn-off. Start the grill and operate for a minimum of 15 minutes on HIGH to burn-off the unit. This will “heat clean” the internal components, dissipate odors and rid it of any foreign matter.

LIGHTING PROCEDURE

1. Verify that all control knobs are turned to the OFF position.
2. Connect LP gas cylinder as per instructions. Turn LP gas cylinder valve to OPEN.
3. Note the indicator marker on the control knob. Push and hold down the control knob on the grill and turn 90 degrees (or 1/4) counter-clockwise SLOWLY (2 to 3 seconds) to HIGH. You should hear a “click” sound to indicate a spark from the igniter, and look for flame to ensure the burner is lit. If it does not, repeat up to three times.
4. If ignition does not occur in 5 seconds, turn the control knob to OFF, wait 5 minutes and repeat lighting procedure. If the above points do not work, follow **Manual Lighting Procedure** instructions.
5. After the burner has caught fire, you are ready to enjoy your grill at your desired temperature!

If the burner goes out during operation, turn the control knobs to the OFF position. Wait five minutes before attempting to relight to allow any accumulated gas to dissipate.

IGNITER FAILURE PROCEDURE

If for any reason your igniter fails after three of four attempts, check the following steps, or start your grill using the manual method.

1. Ensure the control knobs are turned to the OFF position. Allow any accumulated gas to dissipate.
2. After five minutes, check the following:
 - Visually confirm that the igniter is working by pushing the igniter button and looking at the igniter tip for a spark. If no spark, adjust the distance between the igniter (electrode) tip and burner to 4.5 mm (3/16 in).
 - Visually confirm that the burner tube and portholes are not obstructed. If blocked, follow **Care & Maintenance** instructions.
3. If the above points do not work, follow **Troubleshooting** instructions.

MANUAL LIGHTING PROCEDURE

1. Verify that the control knob is turned to the OFF position.
2. Lift one of the Cooking Grids to expose the burners.
3. Connect LP gas cylinder as per instructions. Turn LP gas cylinder valve to OPEN.
4. Note the indicator marker on the control knob. Push in the regulator knob and turn 90 degrees (or 1/4) counter-clockwise to HIGH.
5. Quickly and carefully, use a lit match secured with the lighting rod (included with the grill) to light burners. Access the burners through the cooking grids. Position lit match near side of burner. Do not attempt to light another area of the burner. This can cause injury.

NOTE: Do not use spirit, lighter-fluid or kerosene for lighting or refreshing a fire in your grill.

6. After the burner has caught fire, place the Cooking Grid back into position, and you are ready to enjoy your grill at your desired temperature!

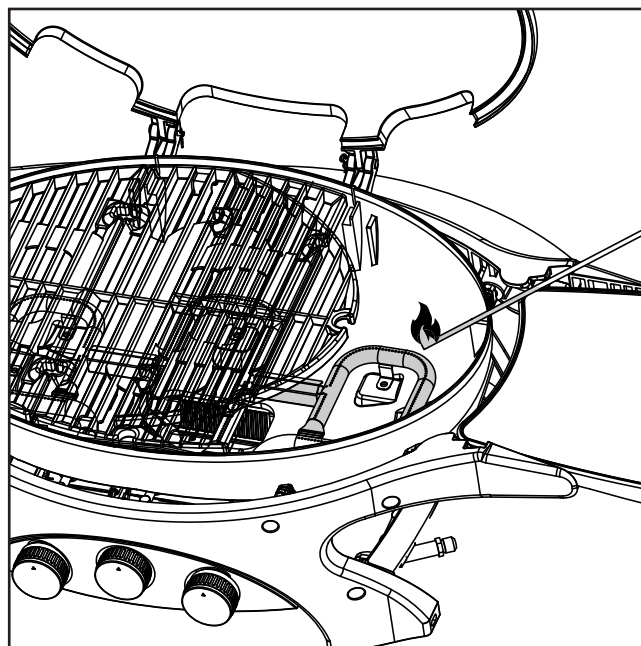

SHUTTING OFF YOUR GRILL

1. When finished cooking, turn LP gas cylinder valve to the CLOSED position, and allow the regulator knob to pop out. This safety feature locks the regulator knob to ensure that the gas is no longer flowing.
2. Turn control knobs to the OFF position.

NOTE: A "poof" sound is normal as the last of the LP gas is burned.

3. Disconnect LP gas cylinder by following the **Disconnect LP Gas Tank** instructions.

WARNING: Allow the grill to cool completely, and remove the gas cylinder, before moving, travel, or for storage.

CARE AND MAINTENANCE

CHECKING THE GAS LEVEL

To check the amount of fuel in the LP gas cylinder, the grill must be in operation. Place your hand at the top of the gas cylinder and slowly move down the side until the cylinder feels cool to the touch. This will indicate the approximate amount of gas in your cylinder; if $\frac{3}{4}$ empty, replace with full gas cylinder.

IMPORTANT: Do not use charcoal briquettes or any flammable material with your grill. Use of such material will void your warranty and may lead to a fire, explosion and bodily harm.

CLEANING FREQUENCY

Any Pit Boss® unit will give you many years of flavorful service with minimum cleaning. Follow these cleaning and maintenance tips to service your grill:

1. BURNER COMPONENTS

- Clean the burner whenever heavy build-up is found, to ensure that there are no signs of blockage (debris, insects) on the burner tube or in the burner portholes. After periods of storage, spiders or small insects can build nests, webs, and lay eggs in the burner tube, obstructing the flow of gas to the burner. A clogged tube can lead to a fire beneath the appliance. If storing the grill or before an extended period of non-use, remove the burner and wrap with aluminum foil to reduce the risk of insects entering the burner holes.
- The burner has been preset for optimal flame performance. A blue flame, possibly with a small yellow tip, is the result of the optimal air and gas mixture. If flames are excessively yellow, orange or irregular, clean the oil and food deposits on the burner surface and the burner portholes to increase airflow.

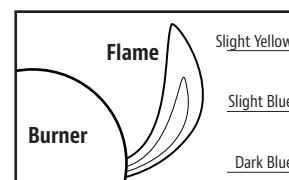

2. GRILL INTERIOR

- Remove any food or build-up from the cooking surface. Best practice is to do this while it is still warm from a previous cook. Grease fires are caused by too much fallen debris on the cooking components of the grill. Clean the inside of your grill on a consistent basis. In the event you experience a grease fire, carefully remove the food, turn the grill off. Lightly sprinkle baking soda, if available.

3. GRILL EXTERIOR

- Check your grease tray often, and clean out after each cool. Keep in mind the type of foods that are cooked. Failure to keep it clean could result in build up and a fat fire. This can be hazardous and may cause damage to the unit.
- All screws and bolts should be checked on a regular basis. Tighten as needed.
- Use a grill cover to protect your grill for complete protection! A cover is your best protection against weather and outside pollutants. When not in use or for long-term storage, keep the unit under a cover in a garage or shed, with the gas cylinder removed (must be stored outdoors).

CLEANING TIME TABLE (NORMAL USE)

ITEM	CLEANING FREQUENCY	CLEANING METHOD
Cooking Grids	After each use	Burn off excess, scrub pad & soapy water
Grease Tray	After each use	Empty, scrub pad & soapy water
Grill Body, Lid	As needed	Non-abrasive cloth & soapy water
Burner Tube, Portholes	Every 5-6 uses	Dust, scrub pad & soapy water
Burners	Every 5-6 uses	Scrub pad & soapy water

TROUBLESHOOTING

Proper cleaning and maintenance will prevent common operational problems. When your grill is operating poorly, or on a less frequent basis, the following troubleshooting tips may be helpful. For FAQ, please visit www.pitboss-grills.com. You may also contact your local dealer or Customer Service for assistance.

WARNING: Always ensure the grill is completely cooled to avoid injury.

PROBLEM	CAUSE	SOLUTION
Burner Will Not Light	The ignition wire is broken	Contact Customer Service for assistance or a replacement part.
	No igniter spark on electrode	Adjust the electrode. Contact Customer Service for assistance or a replacement part.
	No gas supplied	Check the regulator valve. Check connection for leak.
Grease Fire / Frequent Flare-Ups	Grilling fatty meats	Grill fatty meats when the cooking surface is cold, and the knobs are on the "LOW" setting.
	Cooking temperature	Attempt cooking at a lower temperature. Grease does have a flash point. Keep the temperature under 176°C / 350°F when cooking highly greasy food.
	Water sprayed on gas flames	Do not spray water on gas flames.
Burner blows out	No Gas Flow	Check gas fuel connection, and ensure it is open. Replace gas cylinder if empty.
	Gusting or High Winds	Turn front of grill away from wind or increase flame height.
Low heat on "HIGH"	Ports blocked	Clear ports of any obstructions.
	Gas cylinder empty	Refill the gas cylinder.
Gas Leakage	Improper Installation	Turn the regulator knob to the OFF position, and allow the regulator knob to pop out. Remove the gas cylinder. Re-install and tighten. Perform leak test to ensure proper seal. Replace gas cylinder if damaged.
	Seal Failure	Gas cylinder has corroded, rusted, or has been mishandled. Replace gas cylinder.
	Regulator Failure	Regulator needs to be replaced. Contact Customer Service for a replacement part.
Burner Flames Are Yellow Or Orange	Poor Air Flow	Check burner tube and burner ports for spider webs or other obstructions. Follow Care and Maintenance instructions to clean the burner tube.
	Burner Obstruction	
	Grease Cup Is Full, Spilling	Empty grease cup and re-install. Follow Care and Maintenance instructions.
	Regulator Valve Is Off	Check the regulator valve connection to the gas cylinder. Remove, then reinstall. Perform leak test.
	Burner Is Dirty	Turn regulator knob to HIGH for five minutes, and burn-off the unit. Follow Care and Maintenance instructions.

REPLACEMENT PARTS - PB2BPGG & GRILL CART

Part#	Description
1	Lid (x1)
2	Lid Handle (x1)
3	Thermometer Bezel (x1)
4	Thermometer (x1)
5	Cooking Grid (x2)
6	Body Support (x2)
7	Side Shelf (x2)
8	Cotter Pin (x2)
9	Lid Pin (x2)
10	PF Pad (x8)
11	Body (x1)
12	Body Support Beam (x2)
13	Left Burner (x1)
14	Burner Crossover (x1)
15	Right Burner (x1)
16	Grease Tray Support (x1)
17	Grease Tray (x1)
18	Aluminum Foil Liner (x1)
19	Bracket (x1)
20	Valve Assembly (x1)
21	Control Knob (x2)
22	Front Panel (x1)
23	Cart Top (x1)
24	Gas Cylinder Hook (x1)
25	Accessory Tray (x1)
26	Cart Front Panel (x1)
27	Stationary Cart Leg - Front (x1)
28	Stationary Cart Leg - Back (x1)
29	Cart Leg For Wheel - Front (x1)
30	Cart Leg For Wheel - Back (x1)
31	Bottom Shelf (x1)
32	Axle Pin (x2)
33	Wheel (x2)
34	Cart Leg Cap (x2)

Part#	Description
A	Screw (x11)
B	Self-tapping Screw (x3)
C	Screw (x4)
D	Screw (x4)
E	Wheel Bushing (x2)
F	Nut (x5)
G	Cotter Pin (x2)
H	Allen Key (x1)
I	Wrench (x1)

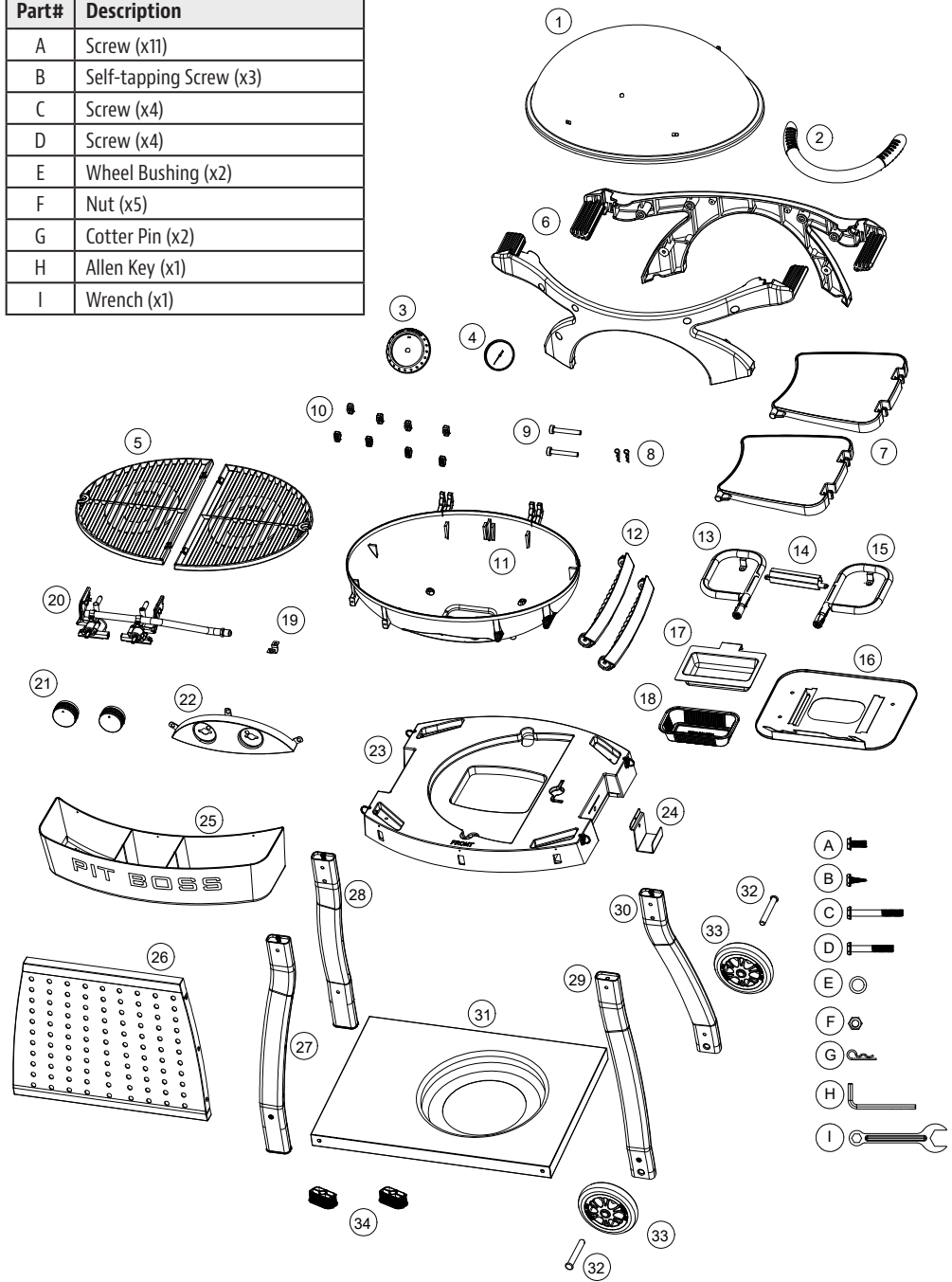

	MODEL	ASSEMBLED (WxDxH)	WEIGHT	COOKING AREA	HEAT INPUT
PB	PB2BPGG	1,175 X 578 X 461 MM / 46.2 X 22.7 X 18.1 IN	18.0 KG / 39.68 LB	1,946 CM ² / 301.6 IN ²	5.2 KW
	GRILL CART	691 X 706 X 645 MM / 27.2 X 27.8 X 25.4 IN	8.0 KG / 17.6 LB		

NOTE: Due to ongoing product development, parts are subject to change without notice.

REPLACEMENT PARTS - PB3BPGG & GRILL CART

Part#	Description
1	Lid (x1)
2	Lid Handle (x1)
3	Thermometer Bezel (x1)
4	Thermometer (x1)
5	Cooking Grid A (x2)
6	Cooking Grid B (x1)
7	Body Support (x2)
8	Side Shelf (x2)
9	Cotter Pin (x2)
10	Lid Pin (x2)
11	PF Pad (x8)
12	Body (x1)
13	Body Support Beam (x2)
14	Left Burner (x1)
15	Burner Crossover (x2)
16	Middle Burner (x1)
17	Right Burner (x1)
18	Grease Tray Support (x1)
19	Grease Tray (x1)
20	Aluminum Foil Liner (x1)
21	Bracket (x1)
22	Valve Assembly (x1)
23	Control Knob (x3)
24	Front Panel (x1)
25	Cart Top (x1)
26	Gas Cylinder Hook (x1)
27	Accessory Tray (x1)
28	Cart Front Panel (x1)
29	Stationary Cart Leg - Front (x1)
30	Stationary Cart Leg - Back (x1)
31	Cart Leg For Wheel - Front (x1)
32	Cart Leg For Wheel - Back (x1)
33	Bottom Shelf (x1)
34	Axle Pin (x2)
35	Wheel (x2)
36	Cart Leg Cap (x2)

Part#	Description
A	Screw (x11)
B	Self-tapping Screw (x5)
C	Screw (x4)
D	Screw (x4)
E	Wheel Bushing (x2)
F	Nut (x5)
G	Cotter Pin (x2)
H	Allen Key (x1)
I	Wrench (x1)

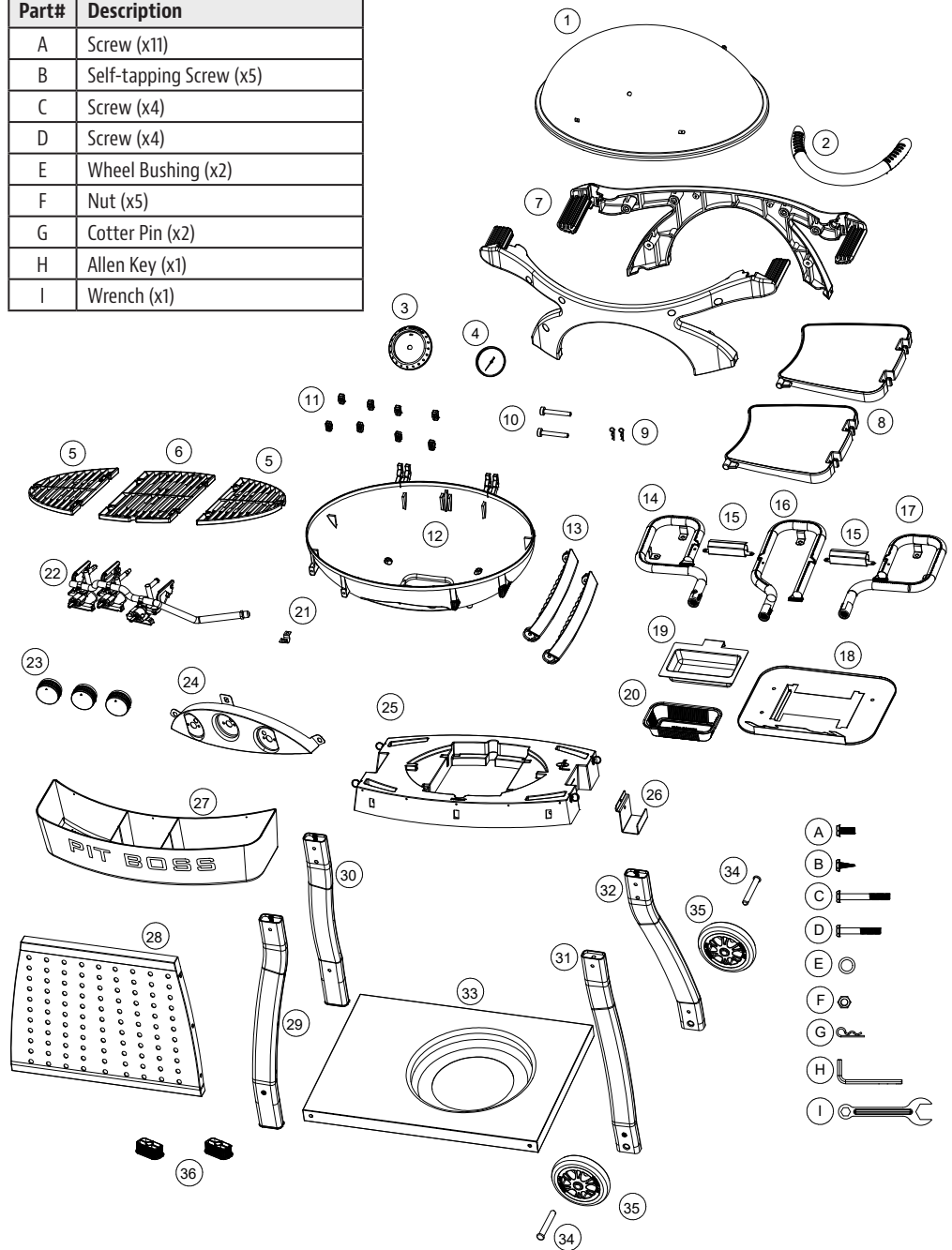

	MODEL	ASSEMBLED (WxDxH)	WEIGHT	COOKING AREA	HEAT INPUT
PB	PB3BPGG	1,332 X 604 X 483 MM / 52.4 X 23.8 X 19.0 IN	24.0 KG / 52.9 LB	2,453 CM ² / 380.2 IN ²	7.5 KW
	GRILL CART	768 X 764 X 645 MM / 30.2 X 30.0 X 25.4 IN	9.8 KG / 21.6 LB		

NOTE: Due to ongoing product development, parts are subject to change without notice.

WARRANTY

CONDITIONS

All gas grills by Pit Boss® Grills, manufactured by Dansons, carry a limited warranty from the date of sale by the original owner. The warranty coverage begins on the original date of purchase and proof of date of purchase, or copy of original bill of sale, is required to validate the warranty. Customers will be subject to parts, shipping, and handling fees if unable to provide proof of the purchase or after the warranty has expired. Dansons carries a five (5) year warranty against defects and workmanship on all parts. Dansons warrants that all part(s) are free of defects in material and workmanship, for the length of use and ownership of the original purchaser. Warranty does not cover damage from wear and tear, such as scratches, dents, dings, chips or minor cosmetic cracks. These aesthetic changes of the grill do not affect its performance. Repair or replacement of any part does not extend past the limited warranty beyond the five (5) year from date of purchase.

During the term of the warranty, Dansons' obligation shall be limited to furnishing a replacement for defective and/or failed components. As long as it is within the warranty period, Dansons' will not charge for repair or replacement for parts returned, freight prepaid, if the part(s) are found by Dansons' to be defective upon examination. Dansons' shall not be liable for transportation charges, labor costs, or export duties. Except as provided in these conditions of warranty, repair or replacement of parts in the manner and for the period of time mentioned heretofore shall constitute the fulfillment of all direct and derivate liabilities and obligations from Dansons to you. Dansons takes every precaution to utilize materials that retard rust. Even with these safeguards, the protective coatings can be compromised by various substances and conditions beyond Dansons' control. High temperatures, excessive humidity, chlorine, industrial fumes, fertilizers, lawn pesticides and salt are some of the substances that can affect metal coatings. For these reasons, the warranty does not cover rust or oxidization, unless there is loss of structural integrity on the grill components. Should any of the above occur, kindly refer to the care and maintenance section to prolong the lifespan of your unit. Dansons recommends the use of a cover when the grill is not in use. This warranty is based on normal domestic use and service of the grill and neither limited warranty coverage's apply for a grill which is used in commercial applications.

There is no written or implied performance warranty on Pit Boss® Grills products, as the manufacturer has no control over the installation, operation, cleaning, maintenance or the type of fuel burned. This warranty will not apply nor will Dansons assume responsibility if your appliance has not been installed, operated, cleaned and maintained in strict accordance with this owner's manual. Any use of gas not outlined in this manual may void the warranty. The warranty does not cover damage or breakage due to misuse, improper handling or modifications. Neither Dansons, or authorized Pit Boss® Grills dealer, accepts responsibility, legal or otherwise, for the incidental or consequential damage to the property or persons resulting from the use of this product. Whether a claim is made against Dansons based on the breach of this warranty or any other type of warranty expressed or implied by law, the manufacturer shall in no event be liable for any special, indirect, consequential or other damages of any nature whatsoever in excess of the original purchase of this product. All warranties by manufacturer are set forth herein and no claim shall be made against manufacturer on any warranty or representation.

Some states do not allow the exclusion or limitation of incidental or consequential damages, or limitations of implied warranties, so the limitations or exclusions set forth in this limited warranty may not apply to you. This limited warranty gives you specific legal rights and you may have other rights, which vary from state to state. Our goods come with guarantees that cannot be excluded under the Australian Consumer Law. You are entitled to a replacement or refund for a major failure and for compensation for any other reasonably foreseeable loss or damage. You are also entitled to have the goods repaired or replaced if the goods fail to be of acceptable quality and the failure does not amount to a major failure.

CONTACT CUSTOMER SERVICE

To order replacement parts, please contact your local Pit Boss® Grills dealer or visit our online store. If you have any questions or problems, contact Customer Service, Monday through Sunday, 4am - 8pm PST (EN/FR/ES).

service@pitboss-grills.com | Toll-Free: 1-877-303-3134 | Toll-Free Fax: 1-877-303-3135

WARRANTY SERVICE

Contact your nearest Pit Boss® Grills dealer for repair or replacement parts. Dansons requires proof of purchase to establish a warranty claim; therefore, retain your original sales receipt or invoice for future reference. The serial and model number of your Pit Boss® can be found directly on the unit. Record numbers below as the label may become worn or illegible.

MODEL

SERIAL NUMBER

DATE OF PURCHASE

AUTHORIZED DEALER